

FOR OFF ROAD/RACE USE ONLY!



Driven TT Rearsets for 2015 Yamaha R-1/M

Part#: DRP-717

INSTALLATION INSTRUCTIONS

Removal

Shifter Side

1. Remove shift rod from shifter.
2. Remove shift lever.
3. Remove 2 m8 bolts from frame bracket and remove plate from bike.

Brake Side

1. Remove 2 m6 bolts holding heal guard / master cylinder.
2. Remove master cylinder plunger pin and retain split pin.
3. Remove exhaust bolt from bracket.
4. Remove 2 m8 bolts and remove frame bracket.
5. Remove rear brake switch and disconnect it from bike.

THE USE OF BLUE LOCTITE IS REQUIRED ON ALL MOUNTING HARDWARE!

Installation

Special note: Brake pedal is using a captured nut/bushing, an impact gun needs to be used when installing on bike.

Shifter Side

1. Install new shift pedal
2. Connect shift rod (left side standard shift right side reverse shift).
3. Install foot peg into left bracket.
4. Install frame bracket using m8 bolts (supplied).
5. Adjust shift pedal with shift rod and tighten safety nut.

Brake Side

1. Install foot peg in frame bracket.
2. Connect master cylinder plunger to brake lever using oem cotter and pin.
3. Install frame bracket to bike.
4. Install master cylinder using 2 m6 bolts supplied.
5. Connect exhaust to exhaust bracket.
6. Use blue Loctite on all bolts and torque all to required setting.
7. Make sure nothing interfere with proper operation of motorcycle.

TOOLS REQUIRED

- 8mm Open End Wrench
- 5mm Hex Key
- 6mm Hex Key
- 8mm Hex Key
- Needle Nose Pliers
- Screw Driver
- Blue Loctite
- Impact Gun

Make final adjustments as necessary and re-check all hardware after the first 500 miles of use.

THIS PRODUCT IS INTENDED TO BE INSTALLED BY A CERTIFIED TECHNICIAN*

FOR OFF ROAD/RACE USE ONLY!

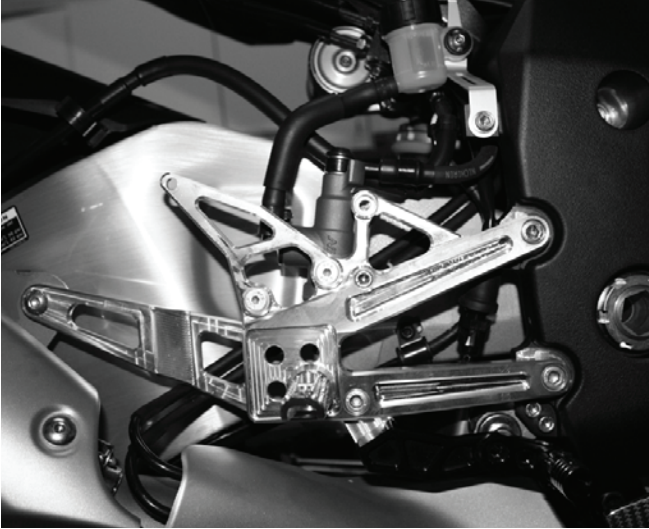

(Fig 1.)

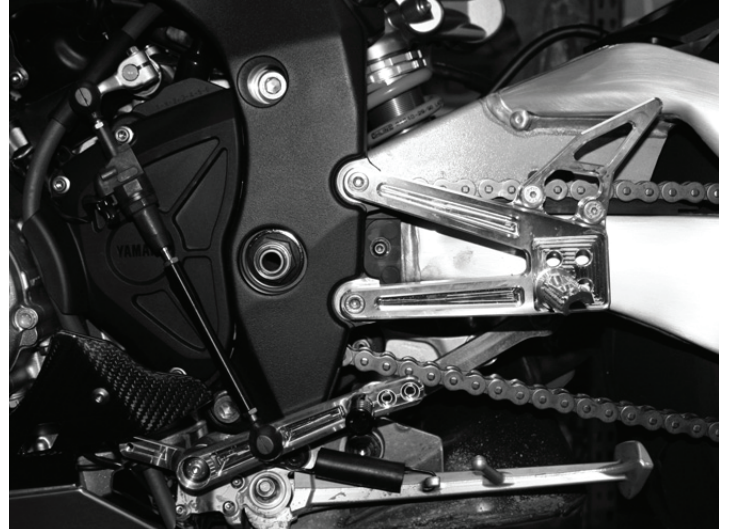

(Fig 2.) Reverse Shift

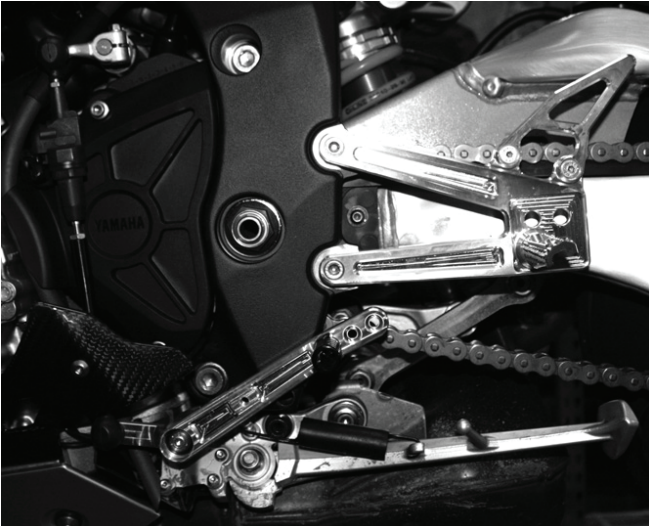

(Fig 3.) Standard Shift

THIS PRODUCT IS INTENDED TO BE INSTALLED BY A CERTIFIED TECHNICIAN*

FOR OFF ROAD/RACE USE ONLY!



Driven TT Rearsets for 2015 Yamaha R-1/M

Part#: **DRP-717**

LEFT SIDE / SHIFTER
A00030

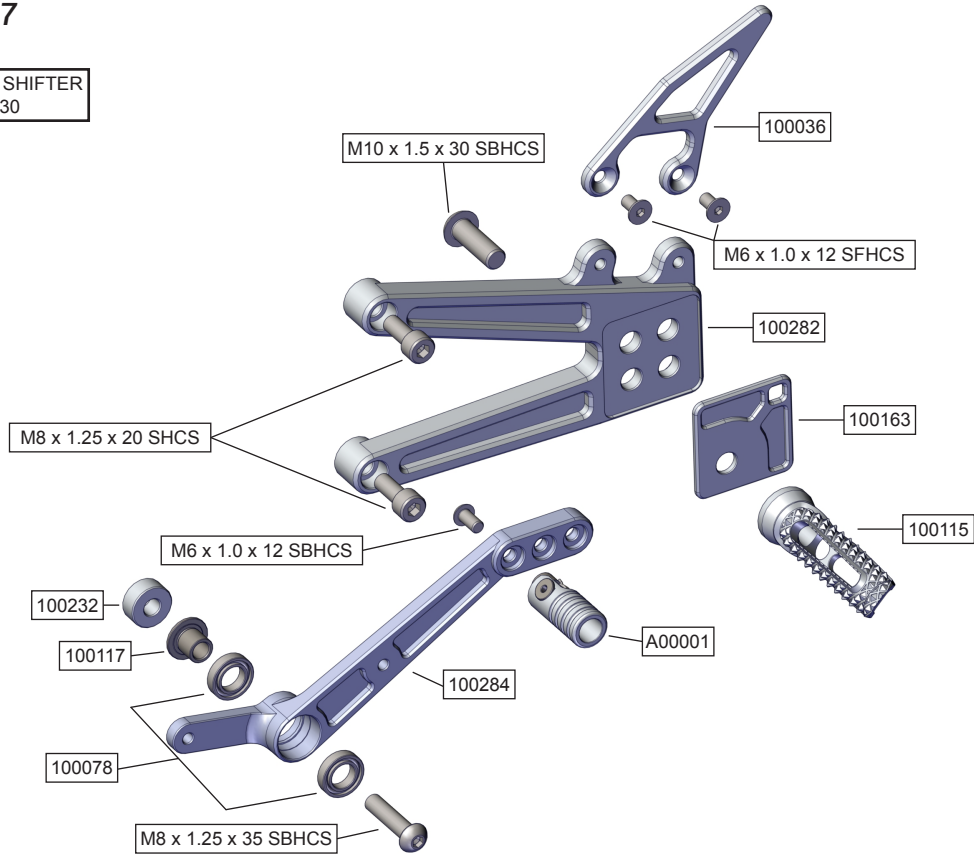

RIGHT SIDE / BRAKE
A00031

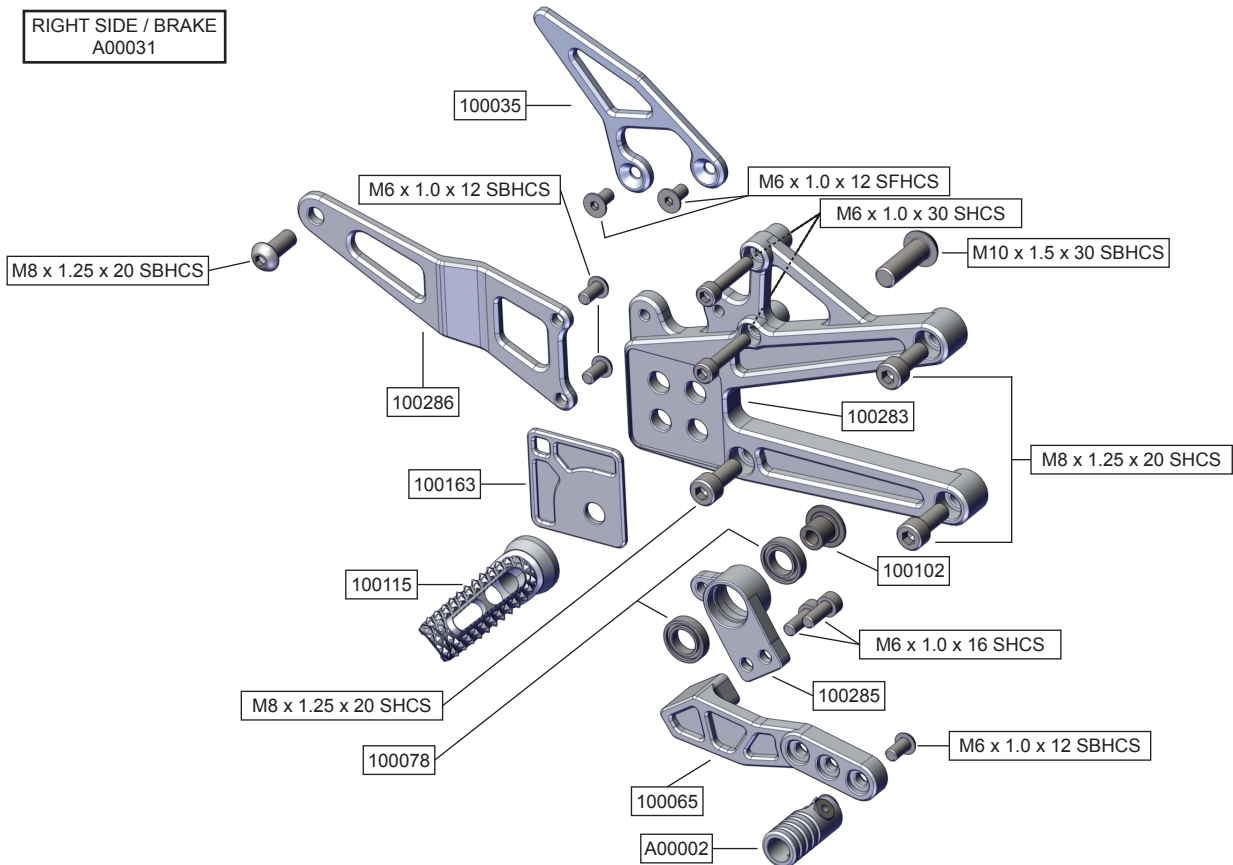

THIS PRODUCT IS INTENDED TO BE INSTALLED BY A CERTIFIED TECHNICIAN*